

Crosswise Convection Gas Convection Oven, 10 GN2/1

ITEM # _____

MODEL # _____

NAME # _____

SIS # _____

AIA # _____

260702 (FCG102)

 Gas Convection Oven
 10x2/1GN, crosswise

Short Form Specification

Item No.

Main structure in stainless steel, with seamless joints in the oven cavity. Double-glazed door with tempered glass. Cavity lighting. Unique air-flow channel system.

Cooking cycles: air convection, convection with 5 stage humidification. Max. temperature of 300°C.

Functional level: base, manual.

"Cross-wise" pan rack suitable for 10x2/1GN or 20x1/1GN. The pan rack, fixed, can be converted into a roll-in rack by using an optional kit. Supplied with n. 1 pan rack, 60mm pitch (made up of n. 2 side hangers).

Main Features

- Racks can be easily removed without the need for special tools.
- Unique air-flow system guarantees perfect distribution of heat throughout the oven cavity.
- Maximum temperature of 300°C.
- Food temperature probe (available as accessory).
- Rapid cooling of oven cavity.
- Halogen lighting and "crosswise" pan supports allow clear and unobstructed view of the products being cooked.
- 5 Stage humidification control, to ensure perfect pastries and succulent roasts.
- Meets the requirements of CE, VDE and DVGW for safety.

Construction

- Access to all components from the front.
- Stainless steel oven cavity with rounded corners.
- Double-glazed door with tempered glass.
- External access door for electrical connections.
- All connections made on the left side below the oven.
- Integrated drain outlet.
- IPx4 water protection.

Included Accessories

- 1 of 60mm pitch side hangers for PNC 922123 10x2/1GN oven (included with the oven)

Optional Accessories

- Water softener with salt for ovens PNC 921305 with automatic regeneration of resin
- Fat filter for gas 10 and 20 1/1 and PNC 921700 2/1 GN ovens (2 filters are necessary for 20-grid ovens)
- Flue condenser for gas ovens PNC 921701 10x1/1-2/1
- Probe for ovens 10x2/1GN PNC 921703
- Guide kit for 1/1GN drain pan PNC 921713
- Pair of grids for whole chicken (8 per grid - 1,2kg each), GN 1/1 PNC 922036
- Open base for 10 GN 2/1 convection oven PNC 922103
- Shelf guides for 10x2/1GN, oven base PNC 922107
- Cupboard base for 10 GN 2/1 convection oven PNC 922110
- Hot cupboard stand for convection oven 10x2/1GN PNC 922113
- 80mm pitch side hangers for 10x2/1GN oven PNC 922117

APPROVAL: _____

- 60mm pitch side hangers for 10x2/1GN oven (included with the oven) PNC 922123
- Feet for ovens 6x1/1GN, 10x1/1 and 2/1GN PNC 922127
- Trolley for 10x1/1GN and 10x2/1GN roll-in rack PNC 922128
- Retractable hose reel spray unit PNC 922170
- External side spray unit (needs to be mounted outside and includes support to be mounted on the oven) PNC 922171
- Pair of baking tray support PNC 922173
- Pair of AISI 304 stainless steel grids, GN 2/1 PNC 922175
- Kit to convert to 10x2/1GN roll-in rack PNC 922202
- Pair of frying baskets PNC 922239
- Grid for whole chicken (8 per grid - 1,2kg each), GN 1/1 PNC 922266
- Kit universal skewer rack and 6 short skewers for Lengthwise and Crosswise ovens PNC 922325
- Universal skewer rack PNC 922326
- 6 short skewers PNC 922328
- Volcano Smoker for lengthwise and crosswise oven PNC 922338

Front

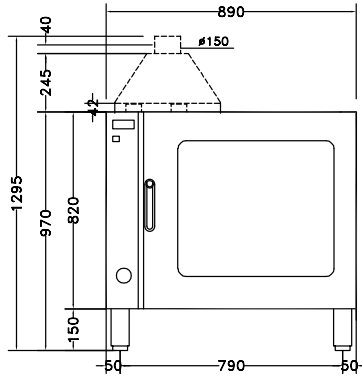

Side

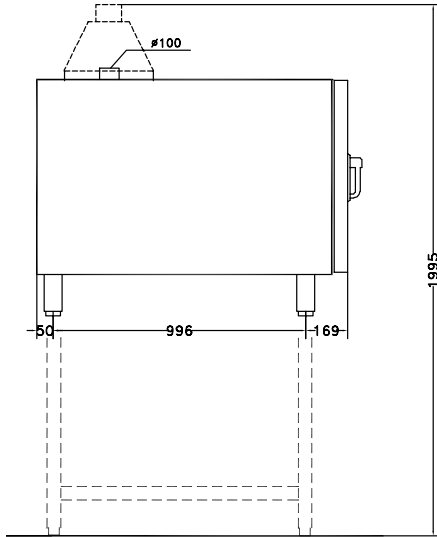

- CW11 = Cold Water inlet 1 (cleaning) G = Gas connection
 CW12 = Cold Water Inlet 2 (steam generator)
 D = Drain
 EI = Electrical inlet (power)

Top

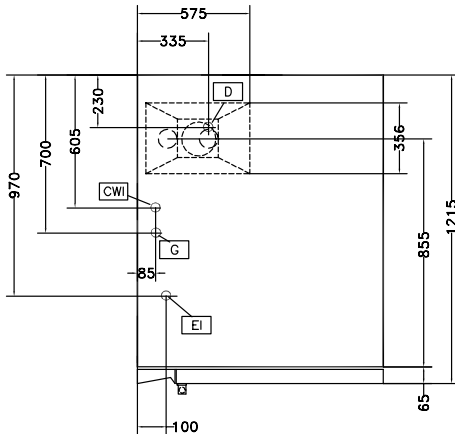

Electric

Supply voltage:	
260702 (FCG102)	220-230 V/1 ph/50 Hz
Auxiliary:	0.5 kW
Electrical power max.:	0.5 kW

Gas

Gas Power:	25 kW
-------------------	-------

Capacity:

Shelf capacity:	10
------------------------	----

Key Information:

External dimensions, Width:	890 mm
External dimensions, Depth:	1215 mm
External dimensions, Height:	970 mm
Net weight:	154 kg
Height adjustment:	80/0 mm
Functional level:	Basic
Type of grids:	2/1 Gastronorm
Runners pitch:	60 mm
Cooking cycles - air-convection:	300 °C